

TECHNICAL GUIDE
ACROW PROP

Any safety provisions as directed by the appropriate governing agencies must be observed when using our products. The pictures in this document are snapshots of situations at different stages of assembly, and therefore are not complete images. For the purpose of safety, they should not be deemed as definitive.

The loads featured in this document, related to the parts of the product, are approximate.

The company reserves the right to introduce any modifications deemed necessary for the technical development of the product.

ALL RIGHTS RESERVED.

Neither all nor part of this document may be reproduced or transmitted in any way by any electronic or mechanical procedure, including photocopy, magnetic recording or any other form of information storage or retrieval system without the written permission.

©COPYRIGHT BY ACROW 2023

DOCUMENT NO:

ACROWPROP_SEP2024_ISSUE C



Technical Manual Release Notes

This page is intended to record all changes to the **ACROW PROP** technical manual pages.

Changes or additions to this manual will be itemised with a brief description and date when the amendments were made.

ISSUE	DATE	Amendment Description
A	09/2023	First Release
B	02/2023	Second Release
C	09/2024	Third Release

Contents

1. TECHNICAL SPECIFICATIONS	1.1
System Description	1.1
Purpose of the Document	1.1
Safety Information	1.1
Safety Information Cont.	1.2
Important Information	1.2
Disclaimer	1.2
Applicable Codes and Standards	1.2
2. GENERAL PRODUCT INFORMATION	2.1
Components	2.2
3. WORKING LOAD LIMITS (WLL)	3.1
Prop WLL	3.2
WLL Vertical Shore	3.3
WLL Raking Shore	3.3
Back Propping WLL	3.4
4. SYSTEM DETAILS	4.1
Acrow Prop System Details	4.2
Extension Measurements	4.3
Acrow Prop Specifications	4.4
Prop Nut	4.5
Prop Pin	4.6
Raking Shore Foot Bracket & Pivot End Adaptor	4.7
U-Head Detachable Spigot	4.7
5. ASSEMBLY DETAILS	5.1
Raking Shore Foot Bracket & Pivot End Adaptor	5.2
U-Head Detachable	5.3
Preparation Prior To Installation	5.4
Using The Correct Prop Pin	5.4
Positioning The Prop Pin	5.5
Only Prop With A Flat Base (End Plate) Can Be Used	5.5
Prop Nut is Fully Screwable	5.6
Care In Tensioning The Prop	5.6
Extending (Installing) The Prop	5.7
Plumbness Of Acrow Prop	5.8
Plumbness Of Acrow Prop	5.9
Prop Support & Bearing	5.9
Measurements To Prevent Differential Settlements & Movement	5.10
Faslework Stability	5.10

Managing Overturning & Sliding	5.11
Controlling Dislodgement	5.12
Achieving Concentric Loading	5.13
Maintaining Safe Loads	5.14
6. TRANSPORT & HANDLING	6.1
Acrow Prop Transport	6.2
7. MAINTENANCE & INSPECTION	7.1
Acrow Prop	7.2
Acrow Prop Inspection	7.3
Prop Pin	7.4

1. Technical Specifications

System Description

A range of adjustable “telescopic props” are designed for multiple uses in the construction industry, including:

- Falsework support: formwork for reinforced concrete slabs and framework beams.
- Raking shores: to brace formwork for columns, walls, and stairs.
- Temporary support: for repair work, canopies, lintels, and the like.

The ACROW PROP consists of an inner and outer tube with a welded top plate, nut and handle, and chain-less prop pin. The high-yield steel **ACROW PROP** is available in six (6) sizes, covering a range from 720mm to 4900mm in height, with axial compression working load limits ranging from 7kN to 50kN. (1kN kN > 102kg).

The revolutionized construction of **ACROW PROP**, has many advantages:

- It is simple and innovative to use, and it is fast to erect in three simple steps by one person.
- Strong and durable. The prop outer tube features a rolled thread, which retains the tube wall thickness and thereby maintains maximum strength.
- Versatile with infinitely variable height adjustment. The telescopic props are capable, of course, of fine adjustment of their overall length.
- A range of connection brackets are designed for multiple applications.
- Reliable and economic. The galvanized finish offers long-term protection against corrosion.
- Fully tested and certified in accordance with AS3610

Purpose of the Document

The purpose of this document is to provide guidelines for the design, safe handling, transport, and installation of the **ACROW PROP** system.

The document also outlines the various components of the system and features illustrations, working load limits, typical assembly arrangements, and safe transport and handling measures.

The information contained in this document is provided as a general guide only and does not replace the need for the design to be reviewed and checked by a qualified person in the field of temporary works design and installation, concrete, steel, building construction, and services.

This material has been prepared in the context of relevant Australian Standards and the National Construction Code (NCC). Users should make themselves aware of any recent changes to these documents referred to therein and to local variations or requirements.

This document is NOT a substitute for site-specific Safe Operation Procedures. It is the responsibility of the installation contractor to prepare safe work method statements and observe and comply with site-specific health and safety regulations, standards, and policies.

Acrow has dedicated engineering services available for project assistance. We can provide design support for clients to determine the best way to specify and document **ACROW PROP**. Our technical experts can identify the most efficient temporary work design that meets project requirements, specifications, and the installation process.

Should the users require any further information or guidance, they are encouraged to contact their local Acrow branch.

Safety Information

This safety information is to draw the user’s attention to possible musculoskeletal disorders as a result of manual handling during assembly and dismantling of the **ACROW PROP** system.

It is recommended that users of the **ACROW PROP** system employ and implement appropriate procedures and control measures to eliminate or control any risk of musculoskeletal disorder or injury while handling.

1. Technical Specifications

Safety Information Cont.

Refer to the Code of Practice on Manual Handling published by the local Workcover Authority or other approved and recognized guidelines for correct and appropriate manual handling procedures.

Important Information

The erection and application instructions contained in this manual are the recommended methods to be used for **ACROW PROP** products.

Please use the information from this manual and its recommended assembly details to ensure the correct installation and performance of the product. Any deviation from the recommended usage will require a separate design and/or verification by Acrow Engineering.

The safe use and application of the system must be in accordance with Australian Standard AS 3610 Formwork for Concrete, Occupational Health & Safety regulations, approved industry codes of practice, and relevant regulatory authority requirements.

The illustrations in these assembly configurations are minimum guidelines only. The combined use of the **ACROW PROP** system with equipment from other Acrow's supplied systems may entail performance issues and therefore require a design check and/or verification by Acrow Engineering or a qualified experienced engineer.

Hazard identification and risk assessments for the erection and dismantling of the system are available from Acrow branches. Site-specific hazards and risk assessments may need to be generated for specific projects.

Disclaimer

1. The photographs and illustrations shown within this manual are intended to be used as a guideline only.
2. In line with Acrow's commitment to continuous product development and improvement, the information contained in this manual may be changed without notice. Please confirm with Acrow Engineering for the latest update.
3. While all reasonable effort has been taken to ensure the accuracy and adequacy of the information contained herein, Acrow accepts no responsibility or liability for any loss or damage suffered by any person acting or refraining from action as a result of this information.

Should users require any expert assistance, they are encouraged to contact the Acrow'' Engineering department.

Applicable Codes and Standards

The structural design information and guide provided in this document are limited to the relevant codes nominated below. It does not include certification of any structures or works associated with a project.

ELEMENT	DESCRIPTION	CODE
LOADING	Structural Design Actions – General Principles	AS/NZS 1170.0-2002
	Structural Design Actions – Permanent, Imposed And Other Actions	AS/NZS 1170.1-2002
STEEL	Cold-Formed Steel Structures	AS 4600-2018
	Steel Structures	AS 4100-2020
FORMWORK	Formwork for Concrete	AS 3610-1995
	Formwork for Concrete Part 1- Specifications	AS 3610.1-2018



2. GENERAL PRODUCT INFORMATION

2. General Product Information

Components

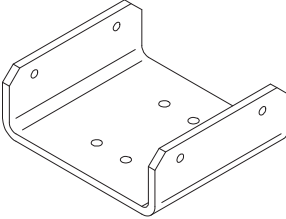
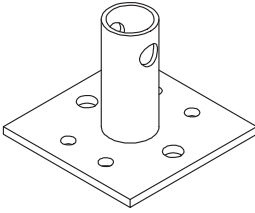
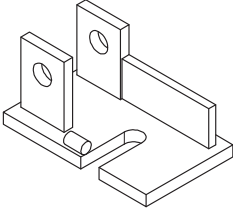
PRODUCT	DESCRIPTION	PRODUCT CODE	MASS (KG) (NOM.)
	Acrow Prop A range of high tensile props designed to be used for falsework support, temporary support and raking shores. Available in 6 sizes covering a range from 720mm to 4900mm with axial compression working load limits ranging from 7kN to 50kN.		
	Acrow Prop No. 00 (720mm- 1000mm)	AP00	10.0
	Acrow Prop No. 0 (1050mm- 1830mm)	AP0	13.0
	Acrow Prop No. 1 (1600mm- 2800mm)	PF1	17.0
	Acrow Prop No. 2 (1900mm- 3400mm)	PF2	20.0
	Acrow Prop No. 3 (2170mm- 3975mm)	PF3	23.0
	Acrow Prop No 4 (3100mm- 4900mm)	PF4	30.0
	U-Head Detachable Spigot Designed to be inserted into Acrow Prop Inner Tube Top-Plate to support joist or bearer.		
	U-Head Detach. Spigot	SCDUHS	5.7
	Pivot End Adapter The Acrow Prop Pivot End Adapter connects Acrow props to the Raking Shore Foot Bracket, using M12 x 30 Grade 8.8 Bolts and Nuts to attach to the prop's base and top plates.		
	Pivot End Adapter	PPEAA	1.8
	Raking Shore Foot Bracket Secured to the base slab to provide attachment for Acrow Props via the Prop Adapter using M20 x 100 Grade 4.6 Hex Bolt and M20 Hex Nyloc Nut		
	Raking Shore Bracket	PTUFB	2.3

3. WORKING LOAD LIMITS (WLL)

3. Working Load Limits (WLL)

Prop WLL

The Acrow Prop specifications and Working Load Limits are summarized in table below:

ACROW PROP	MASS (kg)	EXT. MIN (mm)	EXT. MAX (mm)	OUTER LENGTH (mm)	INNER LENGTH (mm)	HOLES ON INNER	MAX WLL @ MIN EXT. (mm)	MAX WLL @ MAX EXT. (mm)
No. 00	10	720	1000	689	580	4	50.0	40.0
No. 0	13	1050	1830	1039	1039	5	42.5	23.3
No. 1	17	1600	2800	1459	1589	9	34.0	13.0
No. 2	20	1900	3400	1759	1889	11	39.5	10.9
No. 3	23	2170	3975	2059	2163	13	35.8	7.7
No. 4	30	3100	4900	2059	3089	12	18.0	7.0

Each prop is labeled, example below, with information including its number (size), weight, range and axial compressive Working Load Limits.

acrow. ACROW PROP HDG		Nominal weight: 10 kg	
PROP N°	RANGE (m) (NOMINAL)	AXIAL COMPRESSIVE WORKING LOAD LIMIT (W.L.L.) to AS3610	
00	Min 0.720	50.0 kN	(5098 kg)
	Max 1.000	40.0 kN	(4078 kg)
DO NOT INTERPOLATE W.L.L. - FOR W.L.L. AT OTHER EXTENSIONS CONTACT ACROW FORMWORK & SCAFFOLDING			

3. Working Load Limits (WLL)

WLL Vertical Shore

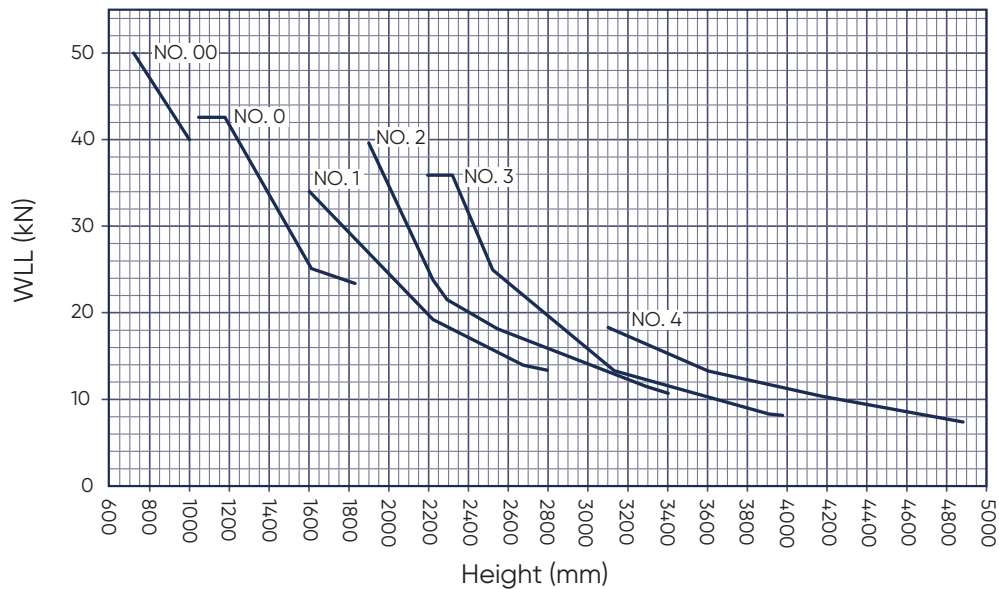

WLL Raking Shore

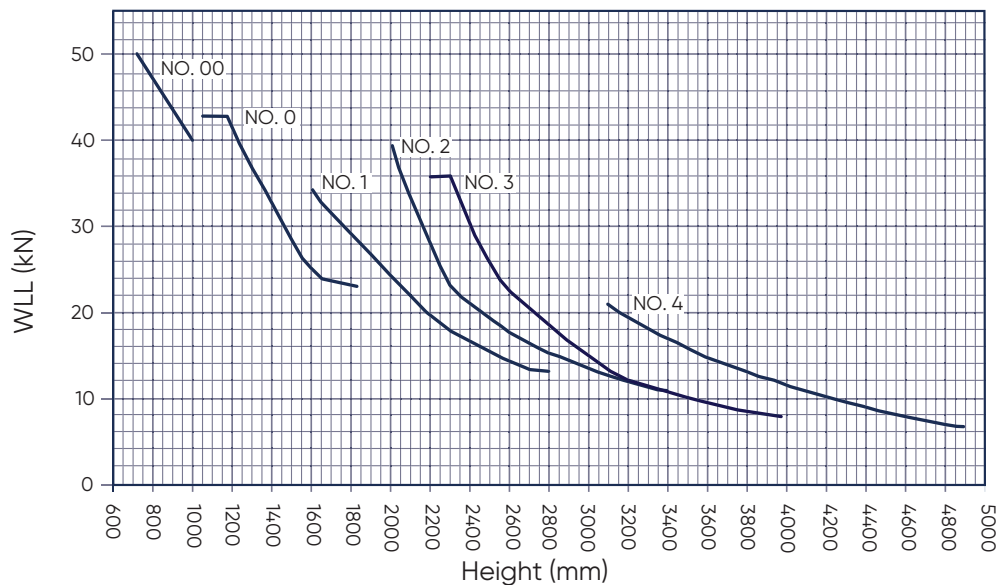

1. Working load limits are applicable to Acrow Props made from gal tube plus or hot dipped galvanized tubes only.
2. Limit state conversion factor = 1.5
3. Refer to AS3610 for acceptable criteria for installation of props and eccentricity of loading. Load eccentricity must not exceed 25mm.
4. For concentric loading and Acrow painted Props please refer to Acrow Engineering.
5. Fixing at the top and bottom plates to ensure proper load-transfer capacity. Props pinned at both ends serve for loads.
6. Maximum capacity is with components in working condition.
7. Initial eccentricity due to the possibility of the strut being set L/200 out of plumb (about the XX axis) has been considered for all eccentricities of load.
8. Raking shore is @ 70° Max

3. Working Load Limits (WLL)

Back Propping WLL

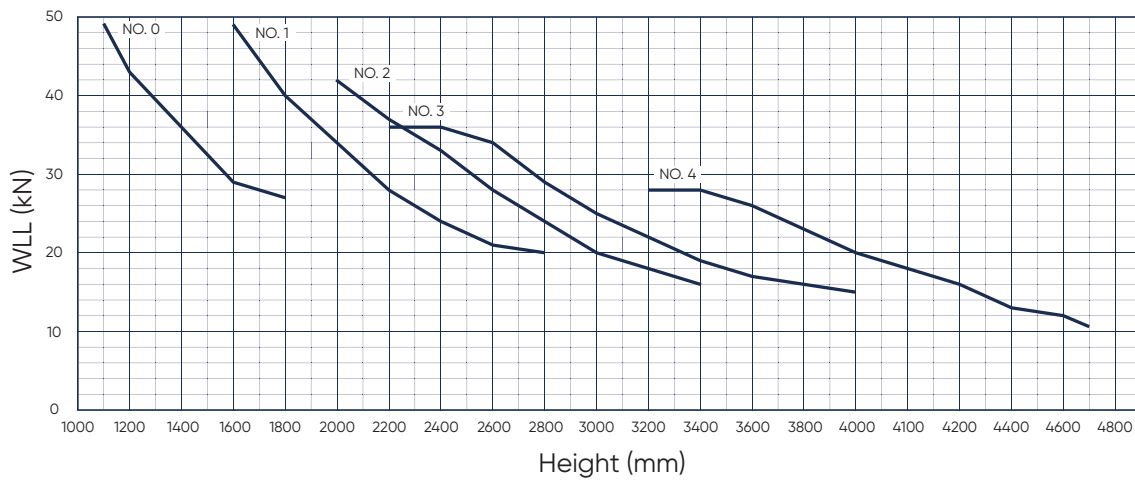

1. Acrow prop working load limit for concentric loads, eccentricity = 0
2. Working load limits are applicable to Acrow Props made from Gal tube Plus or hot dipped galvanized tubes only.
3. Limit state conversion factor = 1.5
4. Fixing at the base and top plates to be suitably capable to transfer loads. Loads are based on a prop pinned at each end.
5. Maximum capacity is with components in working condition.
6. Initial eccentricity due to the possibility of the strut being set L/200 out of plumb (about the XX axis) has been considered for all eccentricities of load.

4. SYSTEM DETAILS

4. System Details

Acrow Prop System Details

The Acrow Prop system consists of four major components designed to be joined or bolted to suit the application:

1. A range of six Telescopic Props
2. U-Head
3. Prop Pivot End Adapter
4. Raking Shore Foot Bracket

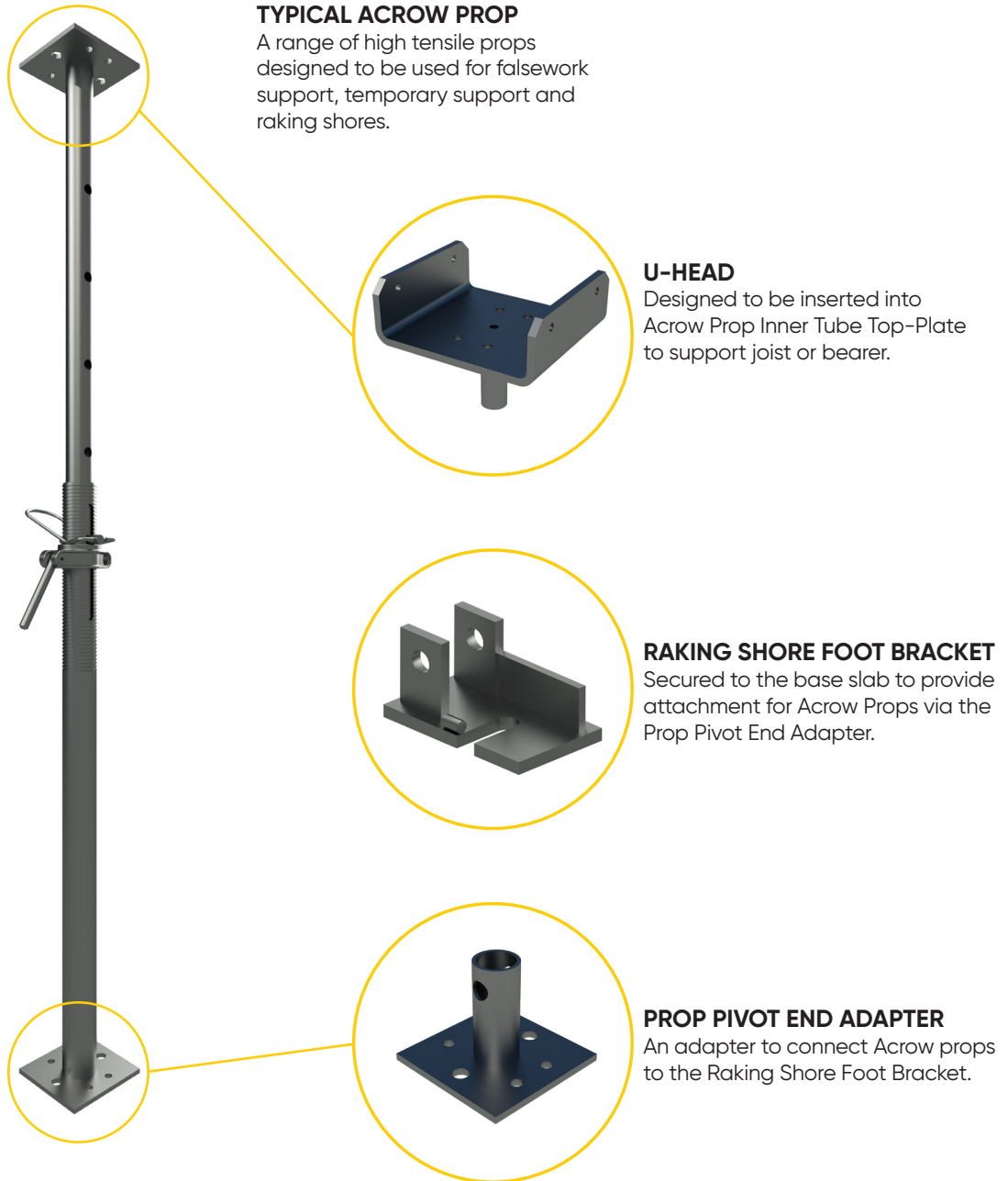

4. System Details

Extension Measurements

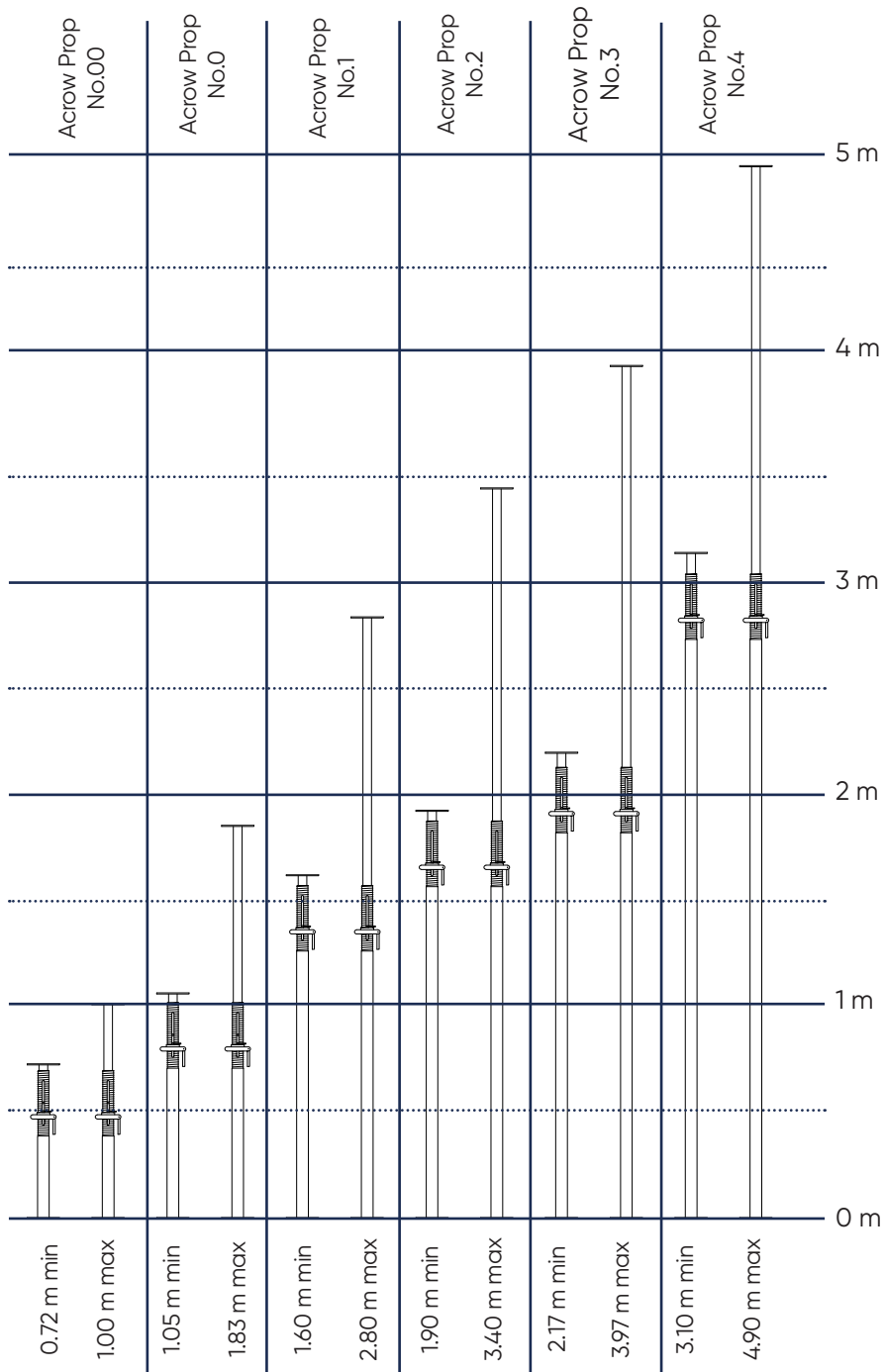

4. System Details

Acrow Prop Specifications

Acrow Prop offer a range of props capable for supporting formwork ranging from 720mm to 4900mm high. Manufactured from high tensile steel, the prop consists of four parts:

1. The outer tube with welded base-plate
2. The inner tube with welded top-plate
3. The nut and handle
4. The chain less prop pin

The prop outer tube is 60.3 OD tube x 3.6mm thick with a 300mm rolled thread and slot. Within the specified range, each prop can be finely adjusted thanks to the rolling thread and slot. The rolled thread retains the wall thickness of the tube, thus maintaining maximum strength. A reduction couplers enables a standard scaffold tube to be connected to the ACROW PROP outer tube for bracing purposes.

The prop inner tube is 48.3 OD x 3.6mm thick for props No. 00 to No. 03 and 3.9mm thick for prop No. 4. The prop inner tube has a series of Ø17.5 holes spaced at 152.5mm increments, which provide the major adjustment for the prop height. Inner tube diameter enables standard scaffold tubes and couplers to be used for bracing purposes.

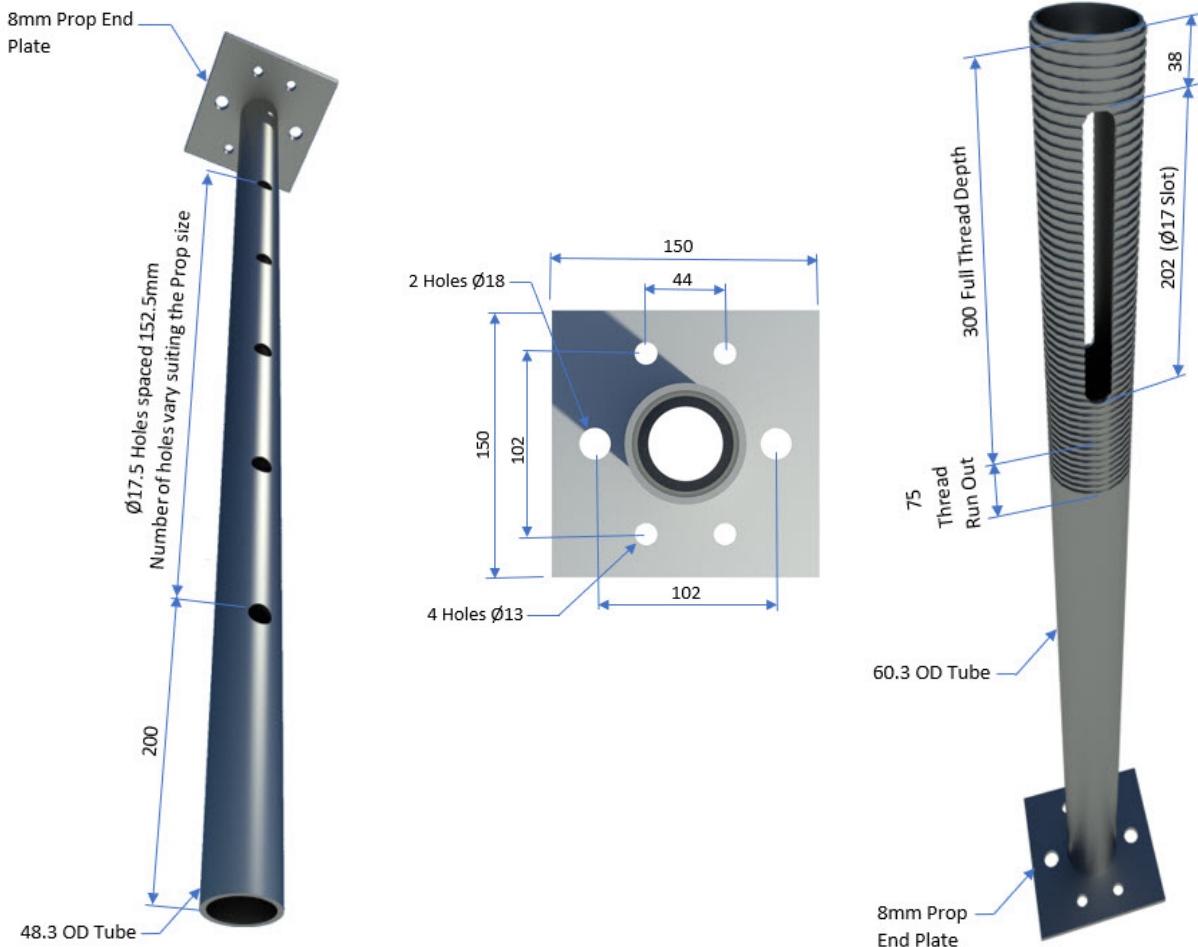

Inner Tube

48.3 OD x 3.6mm-3.9mm thick. The props inner has a series of Ø17.5 holes spaced at 152.5mm increments to provide height adjustment.

Outer Tube

60.3 OD tube x 3.6mm thick. Having rolled thread measuring 300 mm allows for precise adjustment of each prop within the specified range.

4. System Details

Prop Nut

A handle-equipped Grade 480, $\text{Ø}61\text{mm}$ ACME threaded nut made of zinc-plated cast steel. The primary purpose of the prop nut is to engage the outer and inner tubes and finalize the prop height adjustment. The prop nut ACME thread has several benefits, such as faster clamping, fewer threads per axial distance, stronger and longer-lasting resistance to thread wear and stripping, and higher thread shear capacity

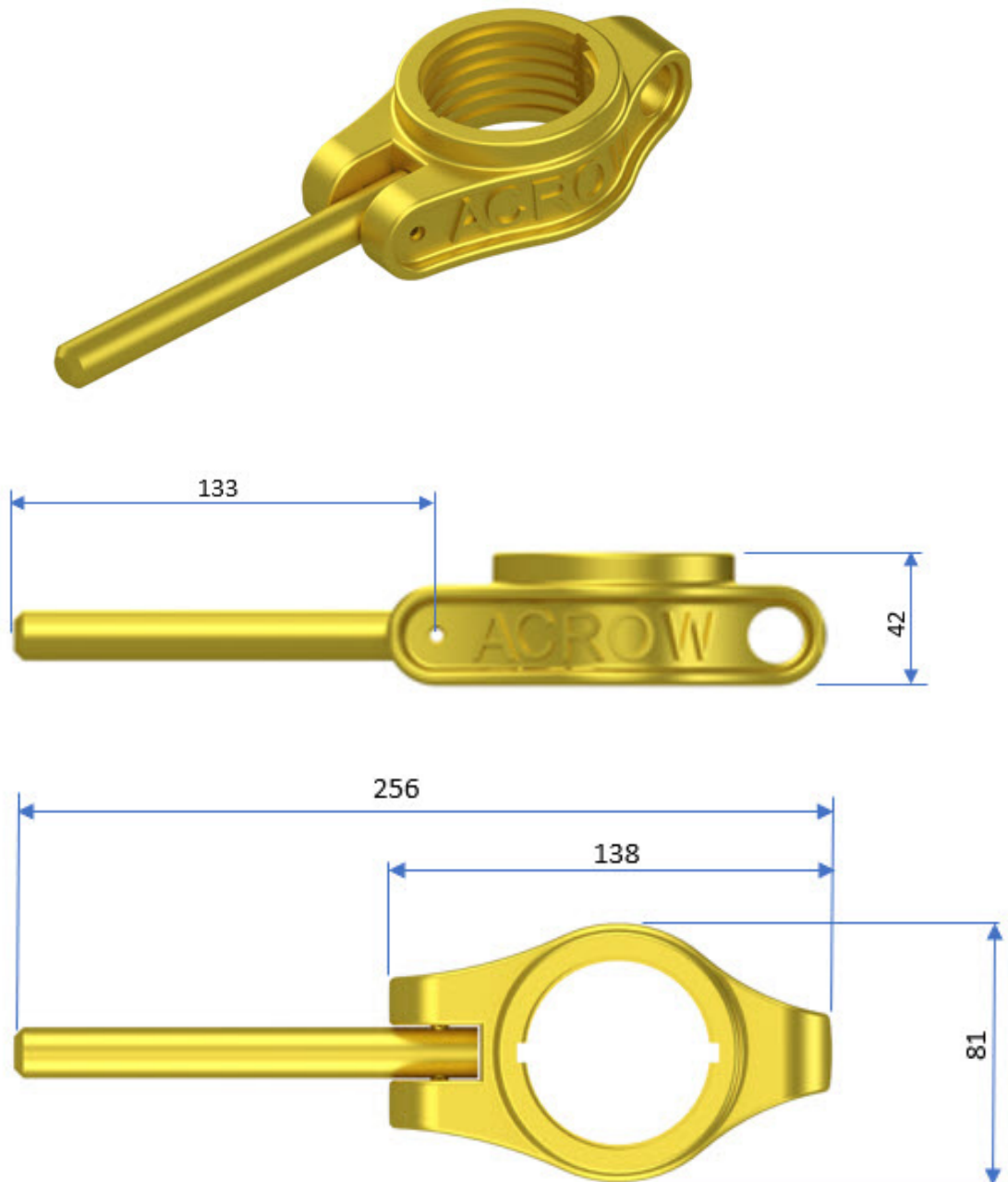

4. System Details

Prop Pin

High tensile pin with solid steel loop. A main feature in the chainless Acrow Prop, structurally engaging both the outer and inner props tubes. The Prop Pin eliminates the need for any tangled or lost chains and reduces loss of pins on the construction site.

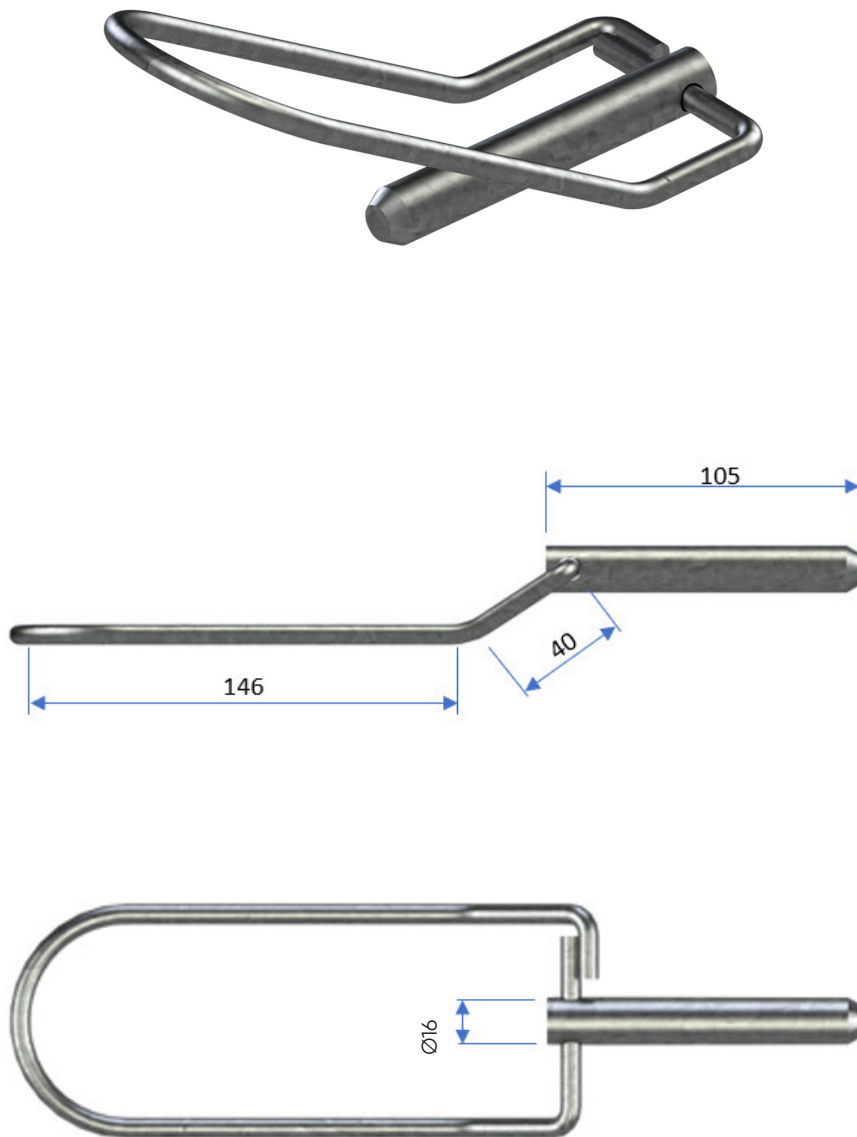

4. System Details

Raking Shore Foot Bracket & Pivot End Adaptor

A bracket and adaptor enable the Acrow prop to provide support and shoring to formwork and other vertical structural members.

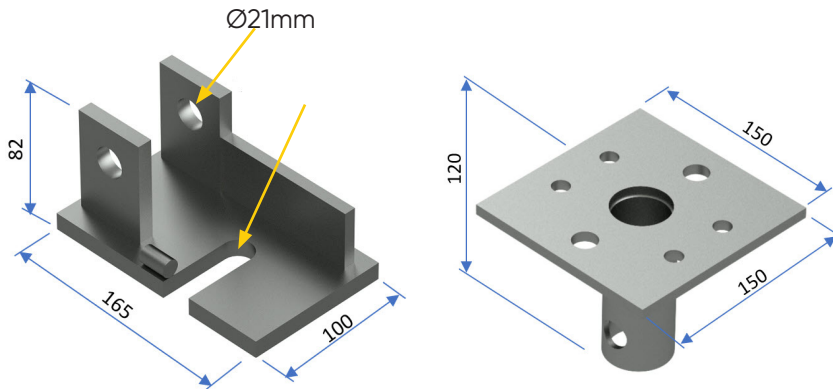

U-Head Detachable Spigot

To support the joist or bearing, the detachable U-Head Spigot is intended to be placed into the Acrow Prop Inner Tube Top-Plate.

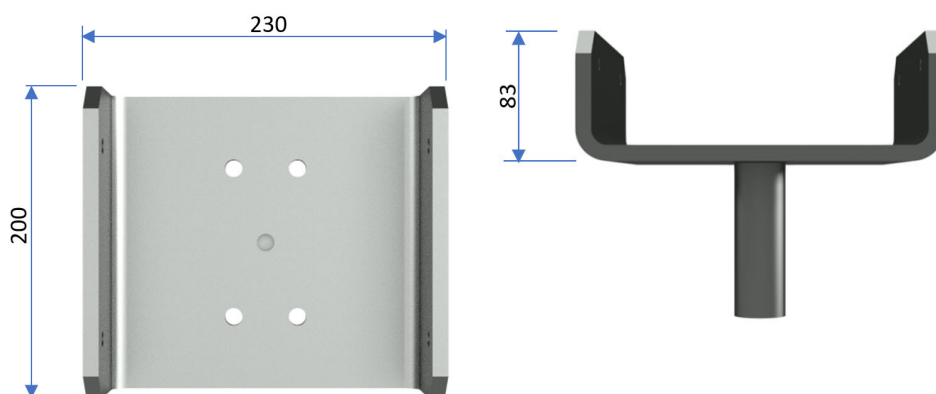

5. ASSEMBLY DETAILS

5. Assembly Details

Raking Shore Foot Bracket & Pivot End Adaptor

The Prop Pivot End Adapter has been designed to allow the Acrow Prop to connect to Acrow's range of formwork solutions and shoring members. For shoring arrangements involving push/pull applications, 2 prop nut assemblies are required.

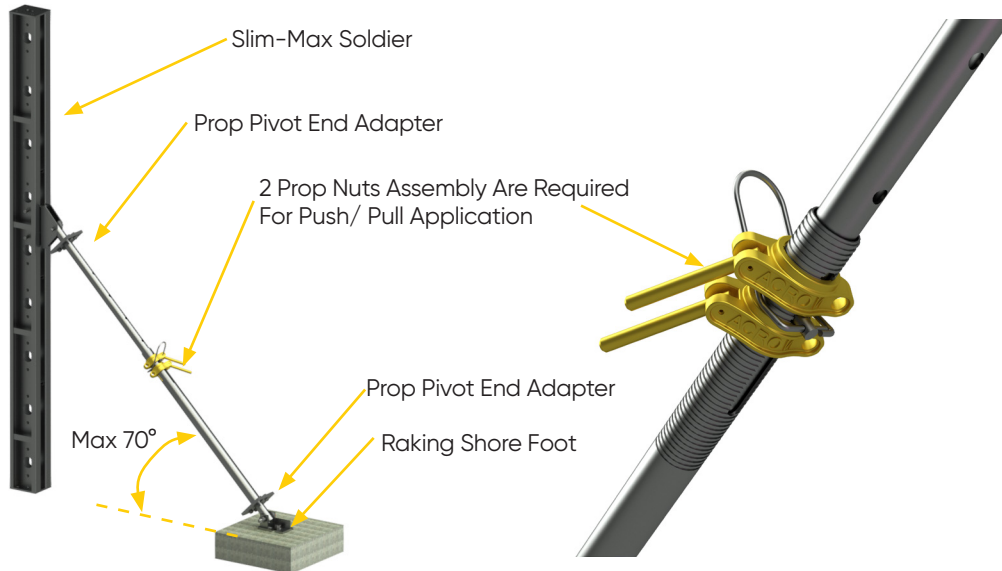

The Prop Pivot End Adapter is bolted to the Acrow Prop end plates using 4 - M12 x 30 GR 4.6 Hex Bolt and Nut. The assembly is pinned and bolted to the Raking Shore Foot Bracket using M20 x 100 GR 4.6 Hex bolt and M20 Hex Nyloc nut. Typical connection details are shown below:

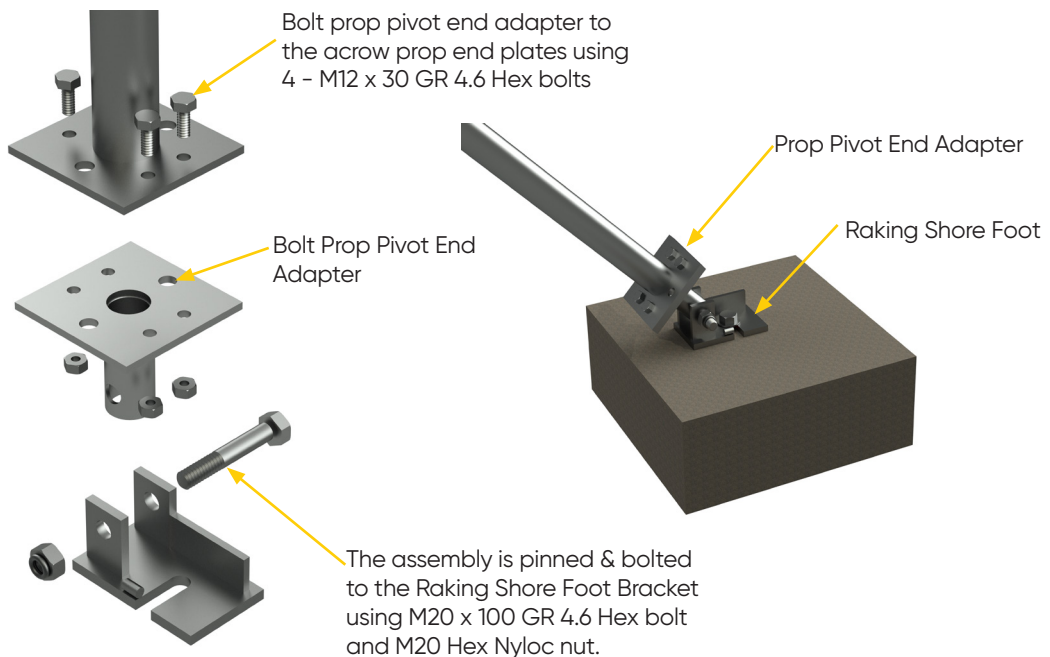

5. Assembly Details

U-Head Detachable

U-Heads don't only support the horizontal bearer, but also ensure the bearers are centrally located to reduce any eccentricity present. The U-Head can be rotated to centre the bearer or the packer can be used for the same purpose.

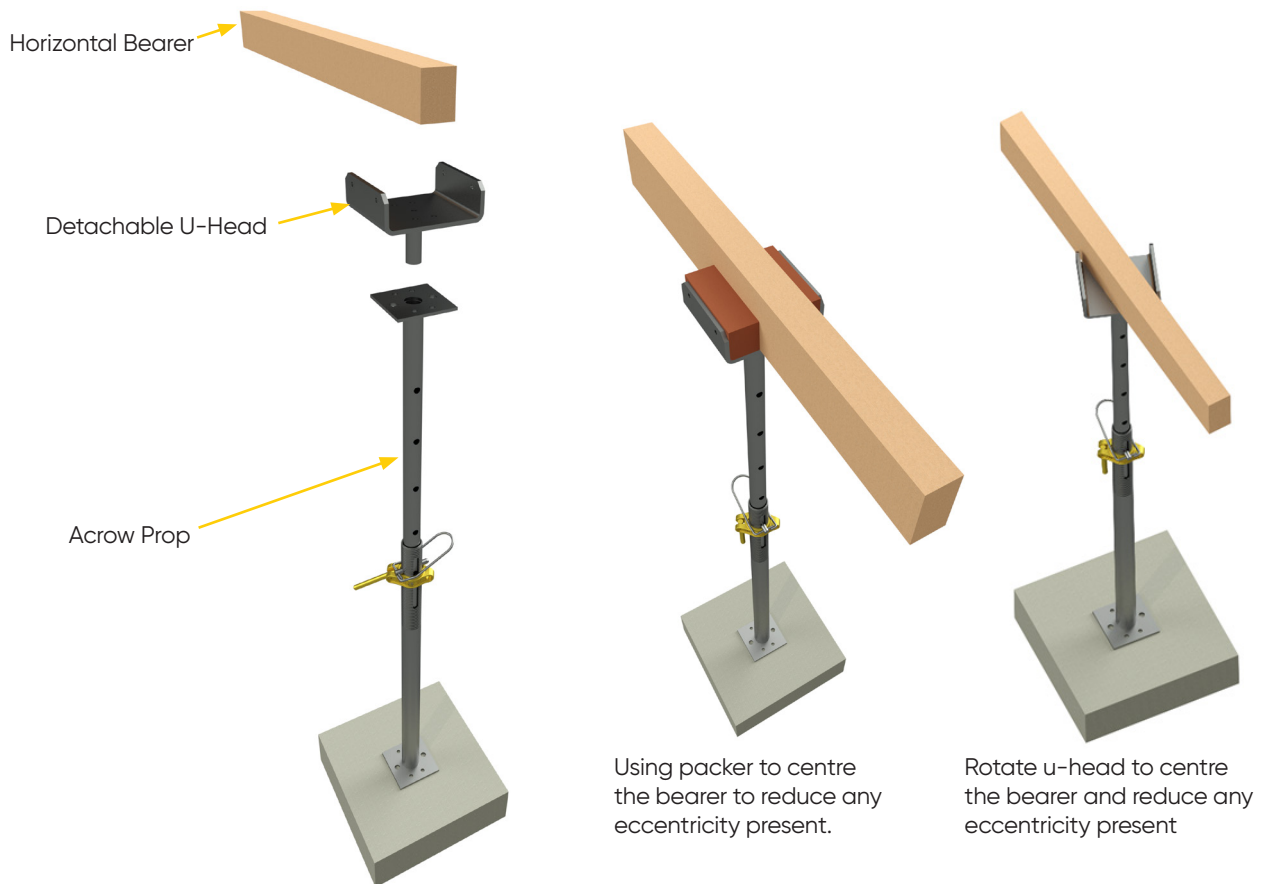

5. Assembly Details

Preparation Prior To Installation

Prior to commencing the installation, ensure:

1. The prop inner and outer prop tubes are straight, no visible deformation and dent exceeding 2mm.
2. The inner tube of the Acrow Prop can slide freely into the Outer tube. Bent props should not be used.
3. The Prop pin and the Loop is attached and assembled, the crank in the loop is facing upwards. This is an essential safety feature of the Acrow's Prop.
4. The fitted with prop pins are the original which are manufactured from high tensile steel. The use of substitute material can result in failure
5. The prop nut is fully movable, intact with no cracks. The nut can be screwed into the full length of the threaded outer tube,
6. The prop head and base plates (End Plates) are flat and perpendicular to the tube to offer correct seating.

Using The Correct Prop Pin

Only use the Acrow Prop pin which is made from high tensile steel. Using any other material will reduce the load bearing capacity of the Acrow prop and can be a safety hazard.

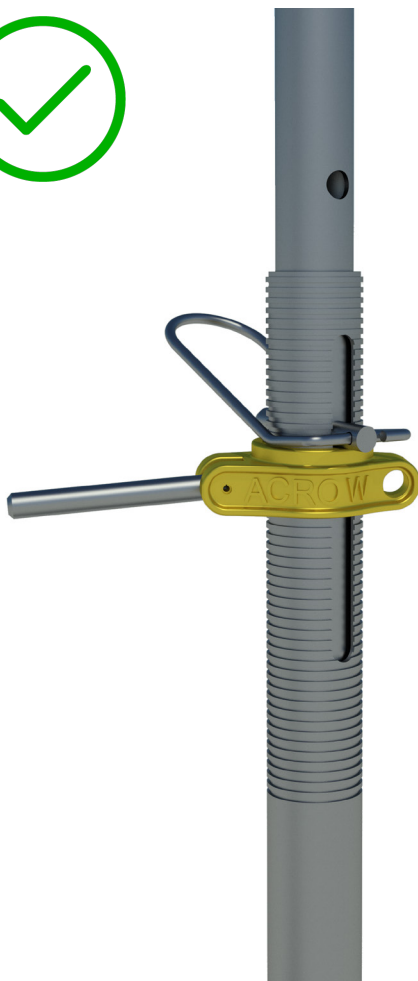

Only use the acrow prop pin which is manufactured from high tensile steel

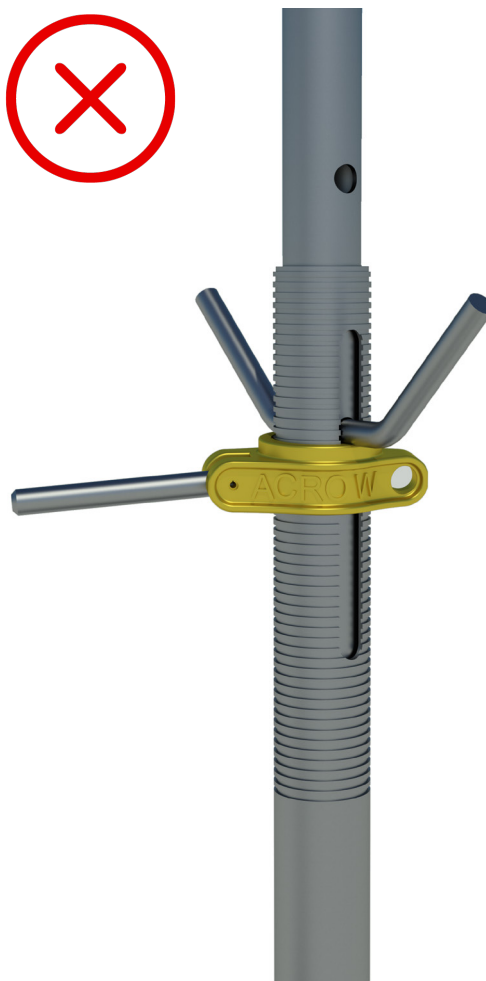

No other material or components should be used

5. Assembly Details

Positioning The Prop Pin

It is important correctly positioning the pin and its loop. The loop should be facing upward where the blow on end of loop will push the loop against prop outer and not dislodge the pin. Incorrectly placing the pin, its loop is facing downward, when the loop is struck by a blow on its end it would result in load being transmitted to end of pin causing it to push out of the prop.

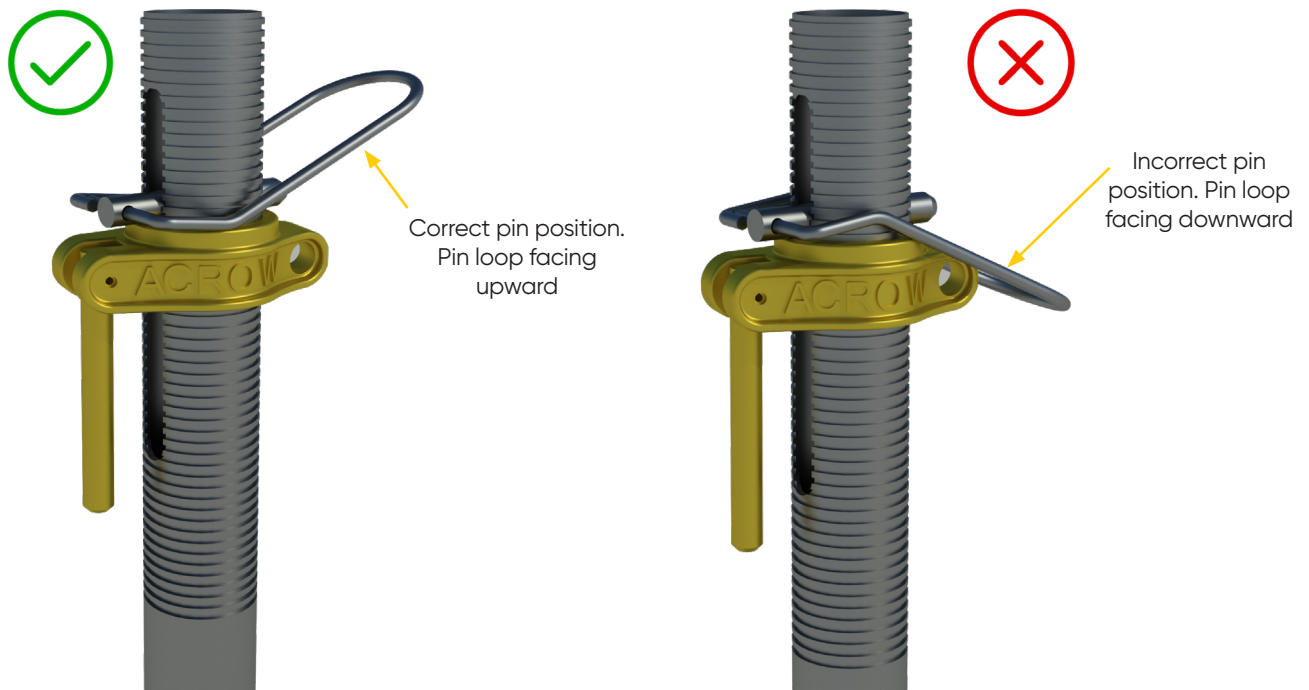

Only Prop With A Flat Base (End Plate) Can Be Used

Twisted, uneven and non-flat end plates will contribute to load eccentricity, reduces the prop load bearing capacity and affect the falsework stability. The maximum allowable camber in the end plate is 1mm in out of plumb.

Props end plate must be flat and not twisted.

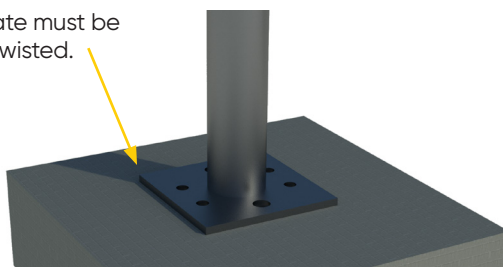

Props with twisted end plates should not be used.

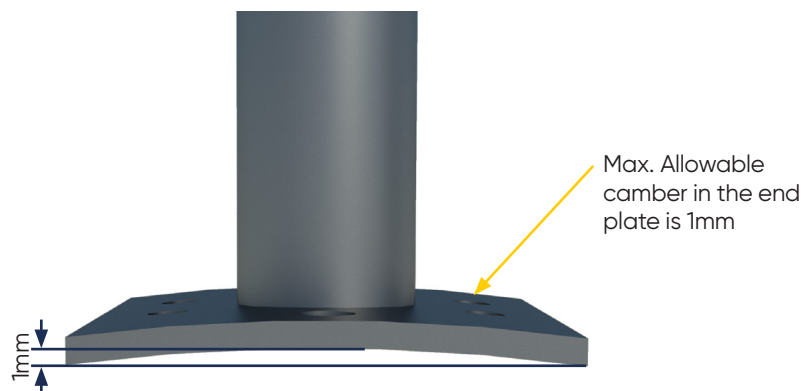
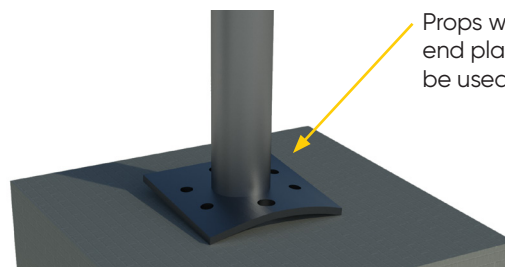

5. Assembly Details

Prop Nut is Fully Screwable

It is essential checking the prop nut is fully screwable and intact with no cracks. The nut needed to be screwed along the full length of the full threaded outer tube and the slot within the tube. The full threaded portion is approx 300mm long with an additional 75mm rolled thread run out. Oil the nut while the prop is installed (in a plumb position), this will ease the screwing of the nut into the outer tube.

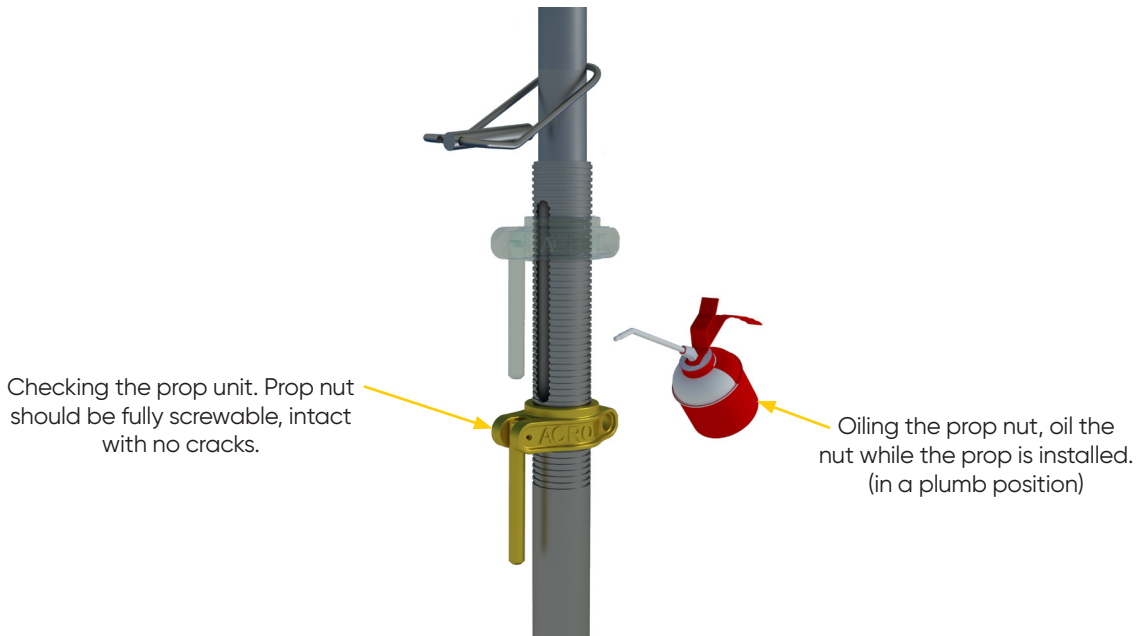

Care In Tensioning The Prop

To ensure the safe operation of the Acrow Prop and to extend its service life, do not use excessive forces, such as hammer or lever, to turn the handle for final prop adjustment. The Acrow prop cannot be used as a jack for lifting structures.

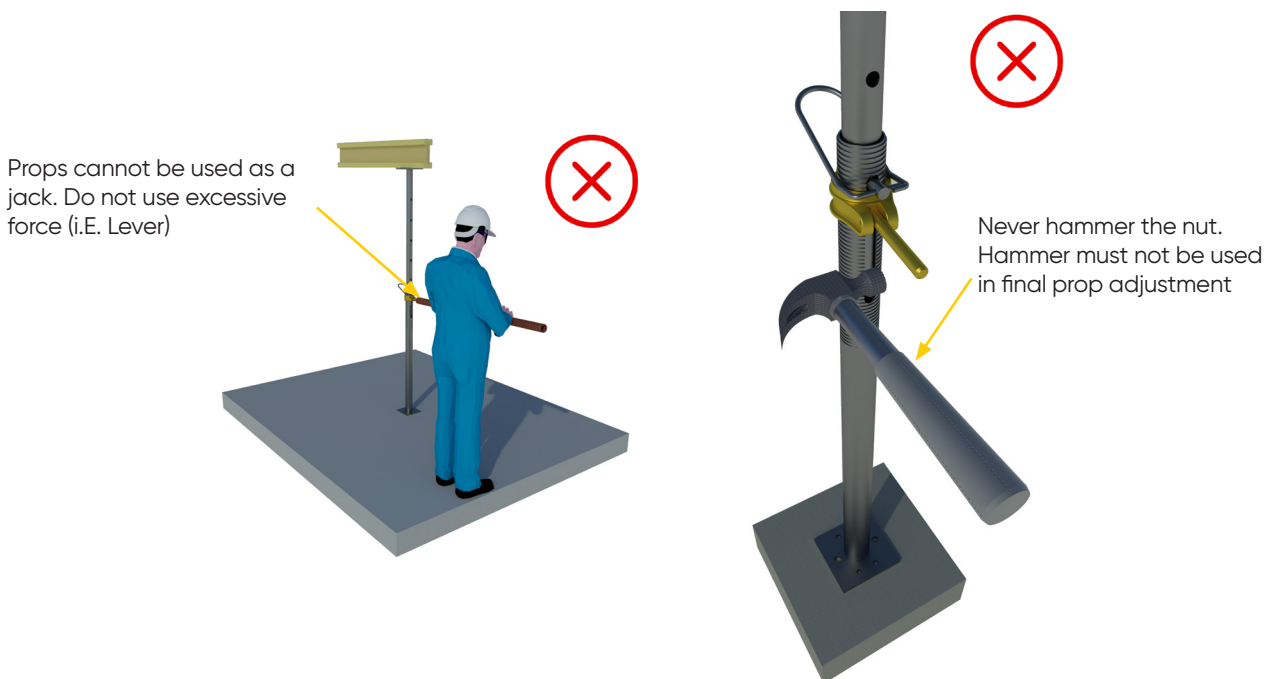

5. Assembly Details

Extending (Installing) The Prop

Three simple steps are required to extend the Prop and install it into its nominated position.

1. Lift inner tube as near as possible to required height. Keep the Outer tube steady. You may place your foot on the Outer tube base to kept it steady.
2. Insert the Prop pin through the slot in the outer tube (above the prop nut) passing through the nearest hole in the inner tube.
3. Turn handle of the nut anti-clock wise for final adjustment.

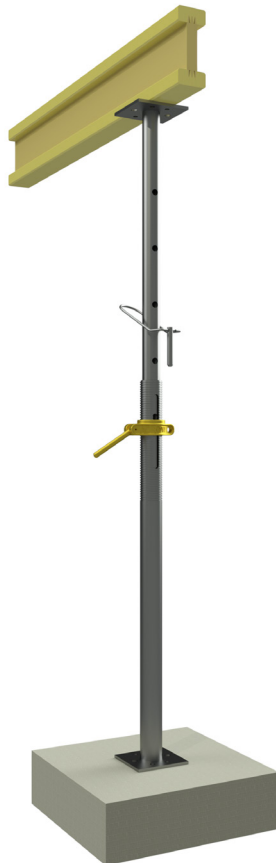

Step 1

Lift inner tube as near as possible to required height.



Step 2

Insert the prop pin through the slot in the outer tube.



Step 3

Turn the nut handle anti-clockwise for final height adjustment.

5. Assembly Details

Plumbness Of Acrow Prop

Props must be installed plumb so the prop can maintain its nominated Working Load Limits. The maximum allowable off-plumb is height / 200.



5. Assembly Details

Plumbness Of Acrow Prop

There are essential installation requirements to ensure the Acrow Props maintain their nominated Working Load Limits and maintain safety during installation and when loads are applied. It is important to adhere to project's specific requirements and related instructions to obtain the correct performance of the product. Any deviation from the recommended usage will require a separate design and/or verification by Acrow Engineering.

The following highlights essential installation requirement:

- Prop support and bearing
- Falsework stability
- Managing overturning and sliding
- Controlling dislodgement
- Must load props concentrically
- Formwork stabilisation
- Maintain safe loads

Prop Support & Bearing

Stability of the Acrow props starts with its foundation. Always refer to the project specific structural design to obtain the ground bearing capacity of the soil and foundation design requirement. The client must ensure that the supporting foundation has adequate bearing capacity to support the load imposed by the props. The principal contractor must ensure client is provided with a level and stable bearing surface for all prop locations. The principal contractor must ensure that the permanent structure has adequate strength to withstand the imposed loads from the scaffold assembly.

The principal contractor must ensure that the supporting foundation is adequately prepared to avoid differential settlement or has the capacity and characteristics properties to limit any differential settlement. The following are the fundamentals for achieving stable foundation:

- A reinforced concrete slab
- Using a Sole Plate

A common stable ground is a reinforced concrete slab. A sole plate of adequate stiffness is an alternative that can be used under props where not bearing on concrete foundations. Sole plates may also still be needed even when the foundation is stable, to prevent damage to surface materials such as tiles.



Use sole plate as measurements to prevent differential settlement

Do not rely on soft ground, consider measurements to control differential settlement

5. Assembly Details

Measurements To Prevent Differential Settlements & Movement

The Acrow Props, part of the falsework, must be supported on sound foundation material which prevent differential settlement and provide adequate bearing capacity to support the applied loads. Differential settlement can occur when the foundation is:

- Partly supported on permanent structure
- Partly on filled uncompact ground

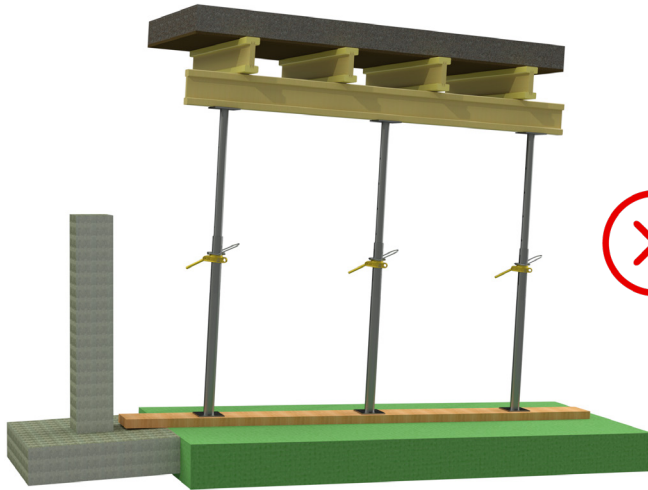

The effect of partly supported on permanent structure

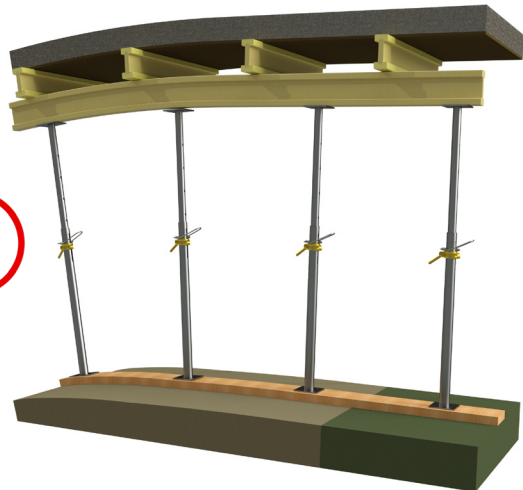

The effect of when props are supported on uncompact ground

Falsework Stability

Falseworks may turnover and or slide if it is subject to uneven loads or horizontal forces such as wind or impact loads from moving equipment. Bracing the props is essential to maintain falsework stability and prevent movement of formwork especially if uneven loads were applied on the falsework.

Typical brace configuration is shown below:

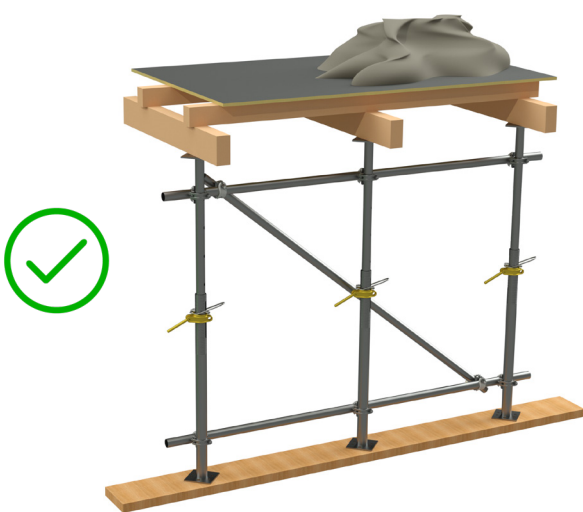

Using bracing for falsework stability



Falseworks may intend to turnover And or slide if it is subject to uneven loads

5. Assembly Details

Managing Overturning & Sliding

Horizontal forces can cause the falsework to overturn or slide.

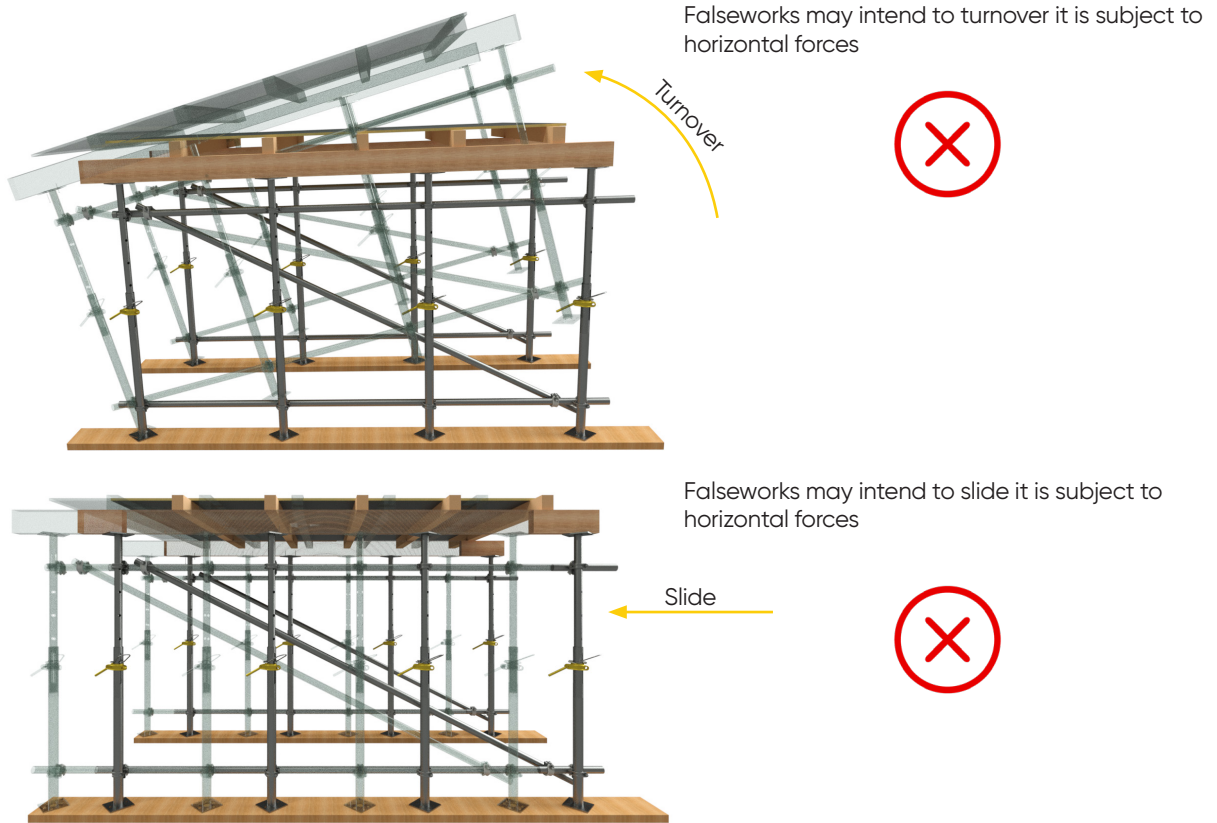

5. Assembly Details

Controlling Dislodgement

In addition to bracing the props, bearers must be nailed or screwed into the prop's head plate (inner tube end plate) to prevent dislodgement of props.



Bearers must be nailed or screwed into the prop's inner tube end plate to prevent dislodgement of props



Brace the props to prevent them from falling in case dislodgement occurs

5. Assembly Details

Achieving Concentric Loading

Bearer should be placed and nailed into the centre of the inner tube end plate to reduce any eccentricity present. The maximum allowable offset of bearer is 25mm from centre of the end plate.

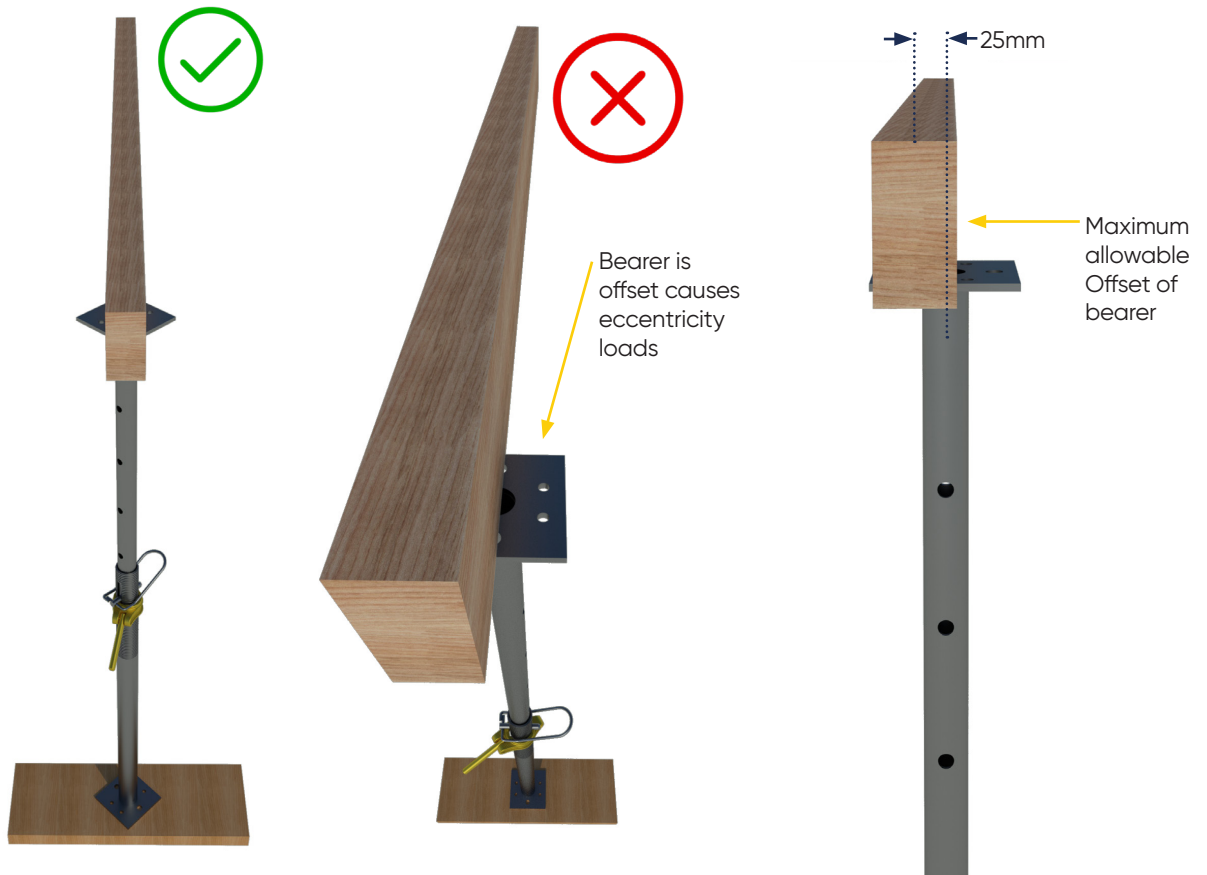

Bearer should be placed and nailed into the centre of the inner tube end plate

5. Assembly Details

Maintaining Safe Loads

Always insure a uniform load distribution. Overloading a single prop can cause the prop to buckle and place additional load on adjacent props causing the entire formwork system to collapse. Do not mound concrete more than the specified limit in the project's specifications.



Apply uniform loads, to prevent prop buckling



The effect of applying, a concentrated load

6. TRANSPORT & HANDLING

6. Transport & Handling

Acrow Prop Transport

The Acrow stillage is used to store a set number of items per a stillage. Items should be stored in a particular way to prevent them from falling off the stillage. The recommended method and process is:

- Stack items next to and on top to each other.
- Only pack and stack similar matching lengths per stillage. Do not mix different sizes or types in one stillage.
- Ensure every stillage load does not exceed the advised table below.
- Secure assembled items onto stillage by using at least two straps or plastic wrapped for enclosed stillages (two straps for enclosed stillage not applicable).
- Refer to Acrow Scaffold Stillage Transport and Manual Handling Document for further stacking and transport recommendations.

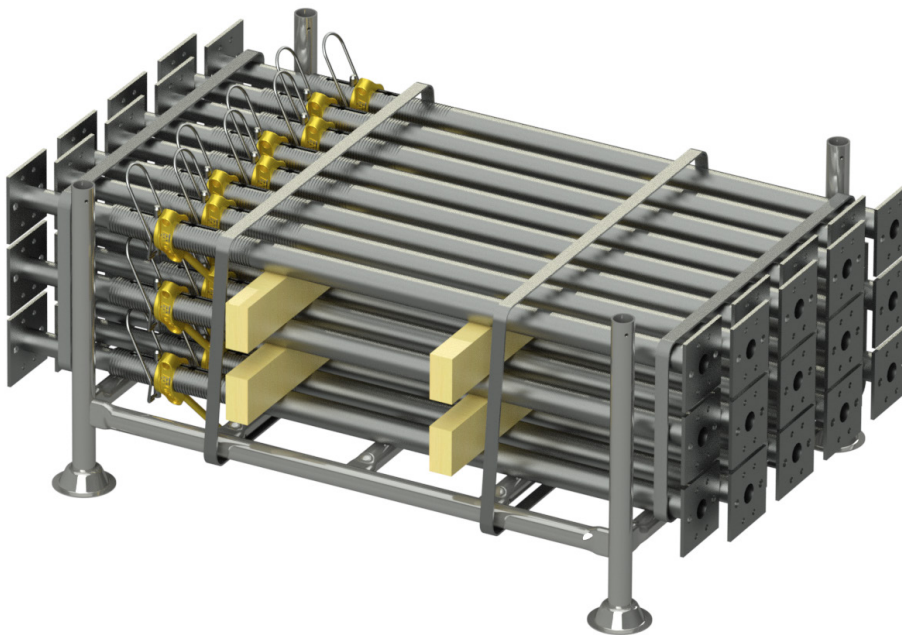

DESCRIPTION	UNIT MASS (KG)	QTY PER STILLAGE	TOTAL MASS PER STILLAGE (KG)	ACROW STILLAGE TYPE
Acrow Prop - No. 00	10	40	400	MP
Acrow Prop - No. 0	13	40	520	MP
Acrow Prop - No. 1	17	40	680	SP or MP
Acrow Prop - No. 2	20	35	700	SP or MP
Acrow Prop - No. 3	23	35	805	SP or MP
Acrow Prop - No. 4	30	35	1050	SP or MP

7. MAINTENANCE & INSPECTION

7. Maintenance & Inspection

Acrow Prop

Concrete deposits. Remove deposits around thread area or on inner or around end plates

Cracked welds in end plate. Isolate and send to workshop for rewelding

Wasting in of slot. Discard outer

Broken or bent Prop pin. Replace with new pin & loop or isolate and send to Workshop for replacement

Inner or outer badly rusted. Isolate and send to workshop for cleaning and repainting or for possible scrapping

Inner must slide freely in outer. If not isolate and send to workshop for rectification

Indentations in tube greater than 4mm. Isolate and send to workshop for removal of dint

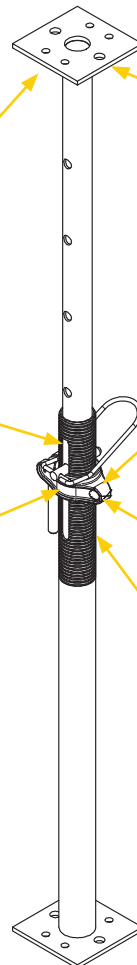

Bent end plate. Isolate and send to workshop for straightening

Handle missing on nut. Isolate and send to workshop for replacement a new handle

Nut is rattly and very loose on thread. Isolate and send to workshop for further checking

Nut must run freely. If it does not, oil thread and run nut up and down thread till movement is easy

Bend in inner or outer. Isolate and send to Workshop for repair

Pin & Loop MUST be assembled as shown. This is extremely important as the crank in the loop facing upwards is a safety feature of the prop.

7. Maintenance & Inspection

Acrow Prop Inspection

NAME: _____

CHECKED DATE: _____

Generally, visual inspection checking for the possible faults listed below. Please tick or cross the checked box.

POSSIBLE FAULTS	DAMAGE LIMITS FOR REPAIR	RECOMMENDED ACTION	CHECKED
Pin bent	Prop Pin must be straight	Replace with new Pin & Loop	
Loop damaged ie: no longer has a defined crank	Loop must have a defined crank	Replace with new Pin & Loop	
Bent inner or outer	Bend in prop fully opened must not exceed L/	Straighten on flypress otherwise scrap	
Bent end plate	None, plates must be straight and square	Straighten	
Indentations of tube	Less than 3.5mm	Remove with insert dolly, if unsuccessful scrap	
Warping in of thread slot	Pin must be able to slide freely in slot	If warping prevents pin sliding freely scrap outer	
Cracked welds on end plates	Any cracked or broken welds unacceptable	Grind back & reweld (See WI-GE-100)	
Broken, bent or non BBS pin	Any broken, bent or non BBS pin unacceptable	Replace with pin & loop	
Inner does not slide freely	Inner must slide freely	Seek cause (bend, indentation etc) and rectify	
Nut difficult to turn	Nut must turn Freely	Ensure thread is clear, oil thread and run nut up & down until Movement is easy Otherwise replace nut	
Concrete deposits	Light deposits on unthreaded outer tube only	Remove any deposits from inner, thread area or end plates	
Rusty appearance	Visual assessment	Repaint/touch up paint	
Nut rattly and generally loose on thread	Nut must run freely but not excessively loose	Problem could be wrong nut ie: SGB nut on Acrow prop or vice versa. Try new nut, if still excessively loose scrap outer* (* See WI-GE-103)	

Issues / Notes:

7. Maintenance & Inspection

Prop Pin

Check loop is not distorted or has been bent straight. If distorted which would prevent it from fitting over a prop outer, isolate and send to workshop for repair. If kink is straightened out then repair it by bending it back to original shape in the workshop.

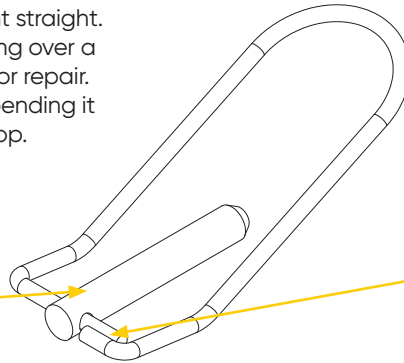

Concrete deposits. Remove deposits particularly around latch pin area and internally at ends of each leg

Check pin is straight. If bent isolate and send to workshop for repair

Check welds not cracked or broken. If cracked or broken, isolate and send to workshop for reweld

NAME: _____

CHECKED DATE: _____

Generally, visual inspection checking for the possible faults listed below. Please tick or cross the checked box.

POSSIBLE FAULTS	DAMAGE LIMITS FOR REPAIR	RECOMMENDED ACTION	CHECKED
Build up of concrete or other matter	No build up permitted	Remove build up with wire brush and clean threads	
Pin bent or damaged	Pin must be straight	If slightly bent (3mm offset max) then straighten, otherwise scrap	
Cracked welds at junction of loop	Cracked welds not permitted	Grind and re-weld. Refer Work Instruction	
Loop distorted	Loop must fit easily over prop outer	Straighten if possible otherwise scrap	
Loop damaged so that kink is no longer defined.	Loop must have defined kink as per drawing/sample	Reshape to original Shape if possible otherwise scrap	
Note: When re-welding cracked welds Work Instruction WI-GE-100 details must be followed			

Issues / Notes:

LOCATIONS

NEW SOUTH WALES

National Head Office
Formwork & Scaffold
2a Mavis Street
Revesby NSW 2212
P: 02 9780 6500
F: 02 9780 6499
E: info@acrow.com.au

Sydney
Screens Head Office
13-15 Vallance Street
St Marys NSW 2760
P: 02 9219 1566

VICTORIA

Melbourne
Formwork, Scaffold & Screens
1651-1657 Centre Road
Springvale VIC 3171
P: 03 9582 2777
F: 03 9582 2790

QUEENSLAND

Brisbane
Formwork & Scaffold
280 Bilsen Road
Geebung QLD 4034
P: 07 3265 2266
F: 07 3865 0277

Beenleigh
Screens & Formwork
2 Morrison Lane
Beenleigh QLD 4207
P: 07 3807 9800

Beenleigh
Industrial Scaffold
22a Spans Road
Beenleigh QLD 4207
P: 07 3442 4000

Gladstone
Industrial Scaffold
48 Chapple Street
Gladstone QLD 4680
P: 07 4972 3200

Mackay
Industrial Scaffold
247 Boundary Road E
Paget Mackay QLD 4740
P: 07 4952 1966

Townsville
Industrial Scaffold
8-12 Webb Drive
Mount St John QLD 4818
P: 1300 11 22 47

SOUTH AUSTRALIA

Adelaide
Formwork & Scaffold
26 Circuit Drive
Hendon SA 5014
P: 08 8359 9700
F: 08 8359 1366

WESTERN AUSTRALIA

Perth
Formwork & Scaffold
11 Jackson Street
Bassendean WA 6054
P: 08 9373 7200
F: 08 9379 3488

TASMANIA

Hobart
Formwork & Scaffold
93 Lampton Avenue
Moonah TAS 7009
P: 03 6277 1212
F: 03 6277 1290

Launceston
Formwork & Scaffold
65 Boland Street
Launceston TAS 7250
P: 03 6324 8282
F: 03 6324 8250



acrow.

ENGINEERING & CONSTRUCTION

Contact

Phone: 1300 138 362

www.acrow.com.au